

AKSA Power Generation has been producing industrial generator sets with an innovative compact design and excellence in quality for over 30 years. AKSA has been providing reliable power through three main production plants and over 15 branch offices worldwide.

General Characteristics

| | |
|----------------------------|------------------|
| Model Name | APD-NG425 |
| Engine Make | PSI (Doosan) |
| Engine Model | 21.9L |
| Alternator Make | Stamford |
| Control Panel Make & Model | DSE 7320 |
| Frequency & Speed | 60Hz, 1800rpm |
| Enclosure Make & Model | AKSA AUL 71A/72A |



Genset Rating

| Engine | Alternator | Voltage | PF | NG Standby Power | NG Standby Current | LP Gas Standby Power | LP Gas Standby Current |
|--------|-------------------|----------|-----|------------------|--------------------|----------------------|------------------------|
| 21.9L | HCI544C (Wnd-311) | 480/277V | 0.8 | 425kW | 639A | 300kW | 451A |
| | HCI544C (Wnd-311) | 240/120V | 0.8 | 425kW | 1279A | 300kW | 902A |
| | HCI544C (Wnd-311) | 208/120V | 0.8 | 425kW | 1476A | 300kW | 1040A |
| | HCI544C (Wnd-17) | 600/347V | 0.8 | 425kW | 511A | 300kW | 361A |

***EPA – Certified for Emergency Stationary Applications**

Stand-by Power (Maximum): Power available at variable load in the event of main power network failure. No over load is permitted.
 Prime Power: Power available at variable load in lieu of a main power network. Overload of 10% is permitted for 1 hour in every 12 hours of operation.
 The above ratings represent the engine performance capabilities to conditions specified in accordance with ISO 8528/5 & ISO3046.
Derating may be required for conditions outside of the test conditions.

Codes & Standards

The Generator set is designed and manufactured in a facility certified to **ISO9001** standards.

The Generator set is designed and manufactured in a facility certified to **ISO14001:2015** standards.

AKSA Power Generation provides **single source responsibility** for the generator set & accessories.

The generator set, with its components, are **prototype tested** and **production tested** according to the UL test program.

The generator set meets **NFPA70, 99, 110, 37** Level 1 when equipped with the necessary accessories and installed per NFPA standards.



*Manufacturer reserves the right to make changes in model, technical specifications, color, equipment and accessories without prior notice.

Engine Data

| | |
|--------------------------|-------------------------|
| Manufacturer | PSI |
| Model | 21.9L |
| Displacement & Cylinders | 21.9 L / 12 Cylinders |
| Engine Type | V-type, 4 Cycle |
| Engine Speed | 1800rpm |
| Engine Standby Power NG | 510kWm |
| Engine Standby Power LP | 352kWm |
| Aspiration | Turbo Charge Air Cooled |
| Compression Ratio | 10.5 : 1 |
| Bore / Stroke | 128 mm / 142 mm |
| Governor type | Electronic |

Fuel System

| | |
|-------------------------------|----------------------|
| Fuel Type | NG, LP Gas/Dual Fuel |
| NG Supply pipe size | 2x2.0" NPTF |
| Maximum EPR Rated Pressure | 6.9 kPa / 1.0 psi |
| Recommended Max Pressure | 2.7 kPa / 11.0 inH2O |
| Recommended Min Pressure | 1.7 kPa / 7.0 inH2O |
| Max LPG vapor Pressure to EPR | 2.7 kPa / 11.0 inH2O |

Fuel Consumption

| | Natural Gas | LP Gas |
|----------------------|--|---------------------|
| Standby Power (100%) | 5375 ft ³ /h 152 m ³ /h | 44 gal/h 166 L/h |

Electric System

| | |
|---------------------|-----------|
| System Voltage (dc) | 24V |
| Battery Qty, Rating | 2 x 120Ah |

Cooling System

| | |
|------------------------------|----------------|
| Radiator Cooling System Type | Closed Circuit |
| Coolant Capacity | 39 gal |
| Cranking Temperature | 160 °F |
| Full Open Temperature | 185 °F |

Exhaust System

| | |
|---|-----------------------|
| Type | Water cooled manifold |
| Max. allowable back pressure | 10.2 kPa |
| Max Turbine Inlet Temperature | 1382 °F |
| Exhaust Gas Flow at Rated Power @ 1350 °F | 2995 cfm |

Air Intake System

| | |
|--|-------------------|
| Combustion Air Required | 829 cfm |
| Max Intake Air Restriction (Clean Element) | 1.2 kPa / 5 inH2O |
| Air Filter Type | Dry Paper Element |

Lubrication System

| | |
|--|--|
| Oil Specifications | SAE 15W-40 Low Ash Gas Engine oil, API CD/CF or higher |
| Oil Capacity, Min-Max | 35 – 42.4 Qts |
| Oil filter; qt, type | 2, Cartridge |
| Min – Max Oil Pressure @1000rpm (Idle) | 13 psi – 44 psi 0.9 bar – 3 bar |



Alternator Data

| | |
|------------------------|-------------------------|
| Manufacturer | Stamford |
| Standards | BS EN 60034 |
| Control System | PMG |
| A.V.R. | MX341 |
| Voltage Regulation | ± 1 % |
| Insulation System | Class H |
| Protection | IP23 |
| Rated Power Factor | 0.8 |
| Stator Winding | Double Layer Concentric |
| Winding Pitch | Two Thirds |
| Winding Leads | 12 |
| Telephone Interference | THF < 2 % |
| Waveform Distortion | No Load < 1.5 % |
| Maximum Over speed | 2250 rev/min |

Battery Charger & Electrical System Data

| | |
|--------------------------|---------------------|
| Manufacturer | ComAp |
| Model | InteliCharger |
| Input Voltage | 85V ~ 264V AC |
| Output Voltage / Current | 13.8V Float / 4A pk |

Jacket Water Heater Data

| | |
|---------------|--------------|
| Manufacturer | Hotstart |
| Model | CTM25110-N00 |
| Input Voltage | 120V |
| Power | 2500W |

Controller Data

| | |
|--------------|------------|
| Manufacturer | DSE |
| Model | 7320 MK II |

Controller Features & Benefits

- Microprocessor controlled, UL & NFPA110 Compatible
- License free PC Software (Non-proprietary Software)
- IP65 rating offers increased resistance to water ingress
- Modules can be integrated to building management systems
- Real time clock provides accurate event log
- Four line back-lit LCD text display
- Five key menu navigation, two wire start/stop at Auto mode
- Front panel editing with PIN protection
- Support up to three remote display modules
- Configurable timers and alarms
- Multiple date and timer scheduler
- Integral PLC editor
- 'Protections disabled' feature
- Load switching (load shedding and dummy load outputs)
- Fully configurable via DSE Configuration Suite PC Software
- SCADA monitoring via DSE Configuration Suite PC Software

Protection

- ✓ Gen. Voltage – under / over
- ✓ Gen. Freq. – under / over
- ✓ Engine Speed – under / over
- ✓ Engine Oil Pressure – low
- ✓ Engine Temp – low / high
- ✓ Battery Voltage – low / high
- ✓ Weak Battery
- ✓ Fail to Start / Stop
- ✓ Charge Alternator Fail
- ✓ Over Current & Load (kW/kVAr)
- ✓ Unbalanced Load
- ✓ Independent Earth Fault
- ✓ Reverse Power
- ✓ Loss of Speed Signal

Instruments

- ✓ Gen. Voltage (L-L/L-N)
- ✓ Gen. Frequency
- ✓ Engine speed
- ✓ Oil Pressure
- ✓ Water Temperature
- ✓ Battery Voltage
- ✓ Run Time
- ✓ Phase Sequence
- ✓ Power monitoring (kWh/kVAh/kVArh)
- ✓ Power (kWh/kVAh/kVArh)
- ✓ Power Factor
- ✓ Generator Current
- ✓ Generator Load (%)
- ✓ Earth Current



Enclosure Features

- ✓ Heavy Duty Steel / Aluminum Structure
- ✓ E-Stop on Enclosure
- ✓ Control Panel Eliminated from Engine Vibrations
- ✓ Standard Sound Attenuation Foam
- ✓ Plastic Covered Corrosion Resistant Locks & Hinges

Enclosure Features

- ✓ Internally Mounted Exhaust System with Rain Cap
- ✓ Coolant Fill Cap
- ✓ Removable Base Frame Lifting Hooks
- ✓ Oil & Coolant Drain Ports
- ✓ Easy Access for Maintenance

Open Skid Gen-Set Dimensions

| | |
|----------------------|----------|
| Length | 158 in |
| Width w/o lift hooks | 83 in |
| Height | 87 in |
| Dry Weight | 11500 lb |

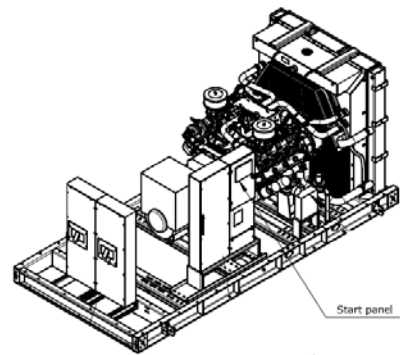

Enclosed Gen-Set Dimensions – Level 1

| | |
|---------------------------|----------|
| Length | 206 in |
| Width w/o lift hooks | 86 in |
| Height | 101 in |
| Dry Weight | 15000 lb |
| Sound Pressure @ 7 meters | 80 dBA |

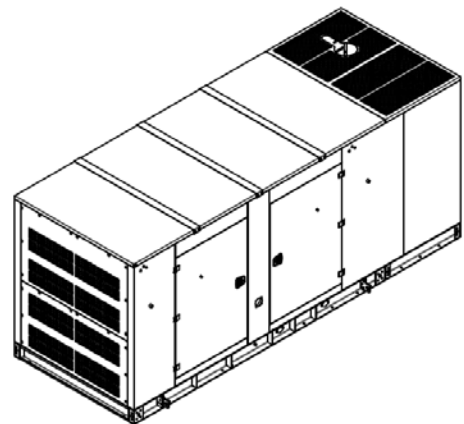

Enclosed Gen-Set Dimensions – Level 2

| | |
|---------------------------|----------|
| Length | 224.6 in |
| Width w/o lift hooks | 86 in |
| Height | 101 in |
| Dry Weight | 15500 lb |
| Sound Pressure @ 7 meters | 77 dBA |

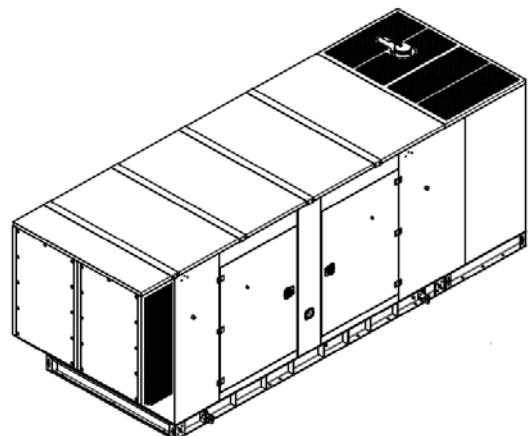

*Manufacturer reserves the right to make changes in model, technical specifications, color, equipment and accessories without prior notice.

**Standard Features & Accessories**

- ✓ UL2200 Certification
- ✓ Heavy Duty Steel Base Frame
- ✓ PMG
- ✓ Engine Jacket Water Heater
- ✓ Battery and Battery Rack
- ✓ Battery Charger
- ✓ Anti Vibration Pads between Engine/Alternator & Base Frame
- ✓ Critical Grade Silencer Inside Enclosure
- ✓ Residential Grade Silencer Set for Open Skid Sets
- ✓ Exhaust outlet rain cap and radiator fill cap
- ✓ Sound Absorb Foam Material for Enclosure
- ✓ Emergency Stop Button
- ✓ Oil Drain Valve
- ✓ Coolant Drain Valve
- ✓ Jacket Water Heater Isolation Valves
- ✓ Flex Fuel Lines
- ✓ Secondary Lock-off Valve on Baseframe
- ✓ Engine Manifold Cover
- ✓ Turbocharger Cover
- ✓ Protection Covers for Rotating Parts
- ✓ Exhaust Insulation Cover
- ✓ Enclosure DC Light
- ✓ Operations Manual
- ✓ 24 Months / 2000 hours Limited Standby Warranty

Optional Accessories

- Main Line CB (3 / 4 Poles – 80% / 100% rated)
- Upsize Alternator
- Anti-condensation Heater
- Voltage Regulation $\pm 0.5\%$ w/MX321 AVR
- Gas Regulator
- NG / LP Auto Changeover Control System
- Low Gas Pressure Alarm
- Low Coolant Level Alarm
- Oil Pan Heater
- Oil Temperature Display on Controller
- Manual Speed Adjust Rheostat
- Manual Voltage Adjust Rheostat
- Remote Annunciator Panel
- Remote Control & Monitoring Panel
- Advanced SMS Messaging
- Control Panel Heater
- Battery Disconnect Switch
- Battery Heater
- Battery Charger 10/20 Amp
- Shunt Trip / Aux Contacts
- Spring Anti-vibration Isolators
- Automatic Transfer Panel (ATS)
- 5 Years / 2000 hours Limited Comprehensive Warranty

AKSA POWER GENERATION USA LLC

371 Exchange Street, West Monroe,
Louisiana, 71292

Tel: 318.855.8377 Fax: 318.855.8381

E-mail: sales@aksausa.com

AKSA Power Generation USA is a member of



KAZANCI HOLDING

DISTRIBUTED BY: